

MODEL: **MELCO** MW-23 BI INOX

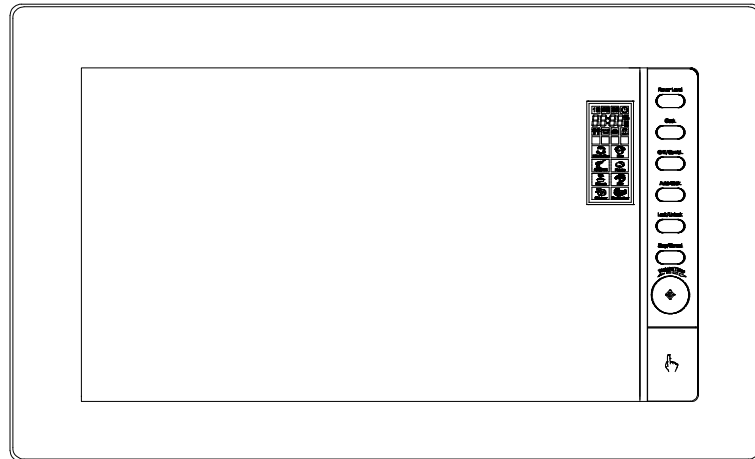

## Microwave Oven    Owner's Manual

Please read these instructions carefully before installing and operating the oven.  
Record in the space below the SERIAL NO. found on the nameplate on your oven and retain  
this information for future reference.  
SERIAL NO.

# PRECAUTIONS TO AVOID POSSIBLE EXPOSURE TO EXCESSIVE MICROWAVE ENERGY

1. Do not attempt to operate this oven with the door open since open door operation can result in harmful exposure to microwave energy. It is important not to defeat or tamper with the safety interlocks.
2. Do not place any object between the oven front face and the door or allow soil or cleaner residue to accumulate on sealing surfaces.
3. Do not operate the oven if it is damaged. It is particularly important that the oven door close properly and that there is no damage to the
  - a. Door (bent),
  - b. Hinges and latches (broken or loosened),
  - c. Door seals and sealing surfaces.
4. The oven should not be adjusted or repaired by anyone except properly qualified service personnel.

## CONTENTS

PRECAUTIONS TO AVOID POSSIBLE EXPOSURE TO EXCESSIVE MICROWAVE ENERGY	1
SPECIFICATIONS*	2
BEFORE YOU CALL FOR SERVICE	2
INSTALLATION	2
GROUNDING INSTRUCTIONS	3
RADIO INTERFERENCE	3
IMPORTANT SAFETY INSTRUCTIONS	3
MICROWAVE COOKING PRINCIPLES	4
UTENSILS GUIDE	5
PART NAMES	5
CONTROL PANEL	6
HOW TO SET THE OVEN CONTROLS	7
Setting Digital Clock	7
Microwave Cooking	7
Grill	7
Combination 1	7
Combination 2	7
Auto Cook	8
Quick Start	8
Multistage Cooking	8
Auto Defrost	9
Child Lock	9
CLEANING AND CARE	9

## SPECIFICATIONS\*

Power Consumption:	230V~50Hz, 1400W(Microwave)
	1000W(Grill)
Output:	900W
Operation Frequency:	2450MHz
Outside Dimensions:	281mm(H)×483mm(W)×369mm(D)
Oven Cavity Dimensions:	220mm(H)×340mm(W)×320mm(D)
Oven Capacity:	23Litres
Cooking Uniformity:	Turntable System
Net Weight:	Approx. 14.1kg

\*SPECIFICATIONS SUBJECT TO CHANGE WITHOUT NOTICE

## BEFORE YOU CALL FOR SERVICE

If the oven fails to operate:

1. Check to ensure that the oven is plugged in securely. If it is not, remove the plug from the outlet, wait 10 seconds, and plug it in again securely.
2. Check for a blown circuit fuse or a tripped main circuit breaker. If these seem to be operating properly, test the outlet with another appliance.
3. Check to ensure that the control panel is

programmed correctly and the timer is set.

4. Check to ensure that the door is securely closed engaging the door safety lock system. Otherwise, the microwave energy will not flow into the oven.

IF NONE OF THE ABOVE RECTIFIES THE SITUATION, THEN CONTACT A QUALIFIED TECHNICIAN. DO NOT TRY TO ADJUST OR REPAIR THE OVEN YOURSELF.

## INSTALLATION

1. Make sure that all the packing materials are removed from the inside of the door.
2. **WARNING:** Check the oven for any damage, such as misaligned or bent door, damaged door seals and sealing surface, broken or loose door hinges and latches and dents inside the cavity or on the door. If there is any damage, do not operate the oven and contact qualified service personnel.
3. This microwave oven must be placed on a flat, stable surface to hold its weight and the heaviest food likely to be cooked in the oven.
4. Do not place the oven where heat, moisture, or high humidity are generated, or near combustible materials.
5. For correct operation, the oven must have sufficient airflow. Allow 20cm of space above the oven, 10cm at back and 5cm at both sides. Do not cover or block any openings on the appliance. Do not remove feet.
6. Do not operate the oven without glass tray, roller support, and shaft in their proper positions.
7. Make sure that the power supply cord is undamaged and does not run under the oven or over any hot or sharp surface.
8. The socket must be readily accessible so that it can be easily unplugged in an emergency.
9. Do not use the oven outdoors.

## GROUNDING INSTRUCTIONS

This appliance must be grounded. This oven is equipped with a cord having a grounding wire with a grounding plug. It must be plugged into a wall receptacle that is properly installed and grounded. In the event of an electrical short circuit, grounding reduces risk of electric shock by providing an escape wire for the electric current. It is recommended that a separate circuit serving only the oven be provided. Using a high voltage is dangerous and may result in a fire or other accident causing oven damage.

**WARNING** Improper use of the grounding plug can result in a risk of electric shock.

### Note

1. If you have any questions about the grounding or electrical instructions, consult a qualified electrician or service person.
2. Neither the manufacturer nor the dealer can accept any liability for damage to the oven or personal injury resulting from failure to observe the electrical connection procedures.

The wires in this cable main are colored in accordance with the following code:

Green and Yellow = EARTH

Blue = NEUTRAL

Brown = LIVE

## RADIO INTERFERENCE

Operation of the microwave oven can cause interference to your radio, TV, or similar equipment.

When there is interference, it may be reduced or eliminated by taking the following measures:

1. Clean door and sealing surface of the oven.
2. Reorient the receiving antenna of radio or television.
3. Relocate the microwave oven with respect to the receiver.
4. Move the microwave oven away from the receiver.
5. Plug the microwave oven into a different outlet so that microwave oven and receiver are on different branch circuits.

## IMPORTANT SAFETY INSTRUCTIONS

When using electrical appliance basic safety precautions should be followed, including the following:

**WARNING:** To reduce the risk of burns, electric shock, fire, injury to persons or exposure to excessive microwave energy:

1. Read all instructions before using the appliance.
2. Use this appliance only for its intended use as described in this manual. Do not use corrosive chemicals or vapors in this appliance. This type of oven is specifically designed to heat, cook or dry food. It is not designed for industrial or laboratory use.
3. Do not operate the oven when empty.
4. Do not operate this appliance if it has a damaged cord or plug, if it is not working properly or if it has been damaged or dropped. If the supply cord is damaged, it must be replaced by the manufacturer or its service agent or a similarly qualified person in order to avoid a hazard
5. Warning: When the appliance is operated in the combination mode, children should only use the oven under adult supervision due to the temperatures generated.
6. **WARNING:** Only allow children to use the oven without supervision when adequate instructions

have been given so that the child is able to use the oven in a safe way and understands the hazards of improper use.

7. To reduce the risk of fire in the oven cavity:
  - a. When heating food in plastic or paper container, check the oven frequently to the possibility of ignition.
  - b. Remove wire twist-ties from paper or plastic bags before placing bag in oven.
  - c. If smoke is observed, switch off or unplug the appliance and keep the door closed in order to stifle any flames.
  - d. Do not use the cavity for storage purposes. Do not leave paper products, cooking utensils or food in the cavity when not in use.
8. **WARNING:** Liquid or other food must not be heated in sealed containers since they are liable to explode.
9. Microwave heating of beverage can result in delayed eruptive boiling, therefore care has to be taken when handle the container.
10. Do not fry food in the oven. Hot oil can damage oven parts and utensils and even result in skin burns.
11. Eggs in their shell and whole hard-boiled eggs should not be heated in microwave ovens since they may explode even after microwave heating has ended.
12. Pierce foods with heavy skins such as potatoes, whole squashes, apples and chestnuts before cooking.
13. The contents of feeding bottles and baby jars should be stirred or shaken and the temperature

should be checked before serving in order to avoid burns.

14. Cooking utensils may become hot because of heat transferred from the heated food. Potholders may be needed to handle the utensil.
15. Utensils should be checked to ensure that they are suitable for use in microwave oven.
16. **WARNING:** It is hazardous for anyone other than a trained person to carry out any service or repair operation which involves the removal of any cover which gives protection against exposure to microwave energy.
17. This product is a Group 2 Class B ISM equipment. The definition of Group 2 which contains all ISM (Industrial, Scientific and Medical) equipment in which radio-frequency energy is intentionally generated and/or used in the form of electromagnetic radiation for the treatment of material, and spark erosion equipment. For Class B equipment is equipment suitable for use in domestic establishments and in establishments directly connected to a low voltage power supply network which supplies buildings used for domestic purpose.
18. This appliance is not intended for use by persons (including children) with reduced physical, sensory or mental capabilities, or lack of experience and knowledge, unless they have been given supervision or instruction concerning use of the appliance by a person responsible for their safety.
19. Children should be supervised to ensure that they do not play with the appliance.

## MICROWAVE COOKING PRINCIPLES

1. Arrange food carefully. Place thickest areas towards outside of dish.
2. Watch cooking time. Cook for the shortest amount of time indicated and add more as needed. Food severely overcooked can smoke or ignite.
3. Cover foods while cooking. Covers prevent spattering and help foods to cook evenly.
4. Turn foods over once during micro waving to speed cooking of such foods as chicken and hamburgers. Large items like roasts must be turned over at least once.
5. Rearrange foods such as meatballs halfway through cooking both from top to bottom and from the center of the dish to the outside.

## UTENSILS GUIDE

- The ideal material for a microwave utensil is transparent to microwave, it allows energy to pass through the container and heat the food.
- Microwave can not penetrate metal, so metal utensils or dishes with metallic trim should not be used.
- Do not use recycled paper products when microwave cooking, as they may contain small metal fragments which may cause sparks and/or fires.
- Round /oval dishes rather than square/oblong ones are recommend, as food in corners tends to overcook.
- Narrow strips of aluminum foil may be used to prevent overcooking of exposed areas. But be careful don't use too much and keep a distance of 1 inch (2.54cm) between foil and cavity.

The list below is a general guide to help you select the correct utensils.

COOKWARE	MICROWAVE	GRILL	COMBINATION
Heat-Resistant Glass	Yes	Yes	Yes
Non Heat-Resistant Glass	No	No	No
Heat-Resistant Ceramics	Yes	Yes	Yes
Microwave-Safe Plastic Dish	Yes	No	No
Kitchen Paper	Yes	No	No
Metal Tray	No	Yes	No
Metal Rack	No	Yes	No
Aluminum Foil & Foil Containers	No	Yes	No

## PART NAMES

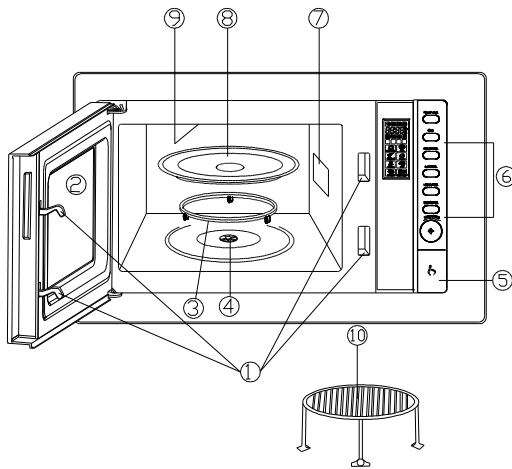

- Door Safety Lock System
- Oven Window
- Roller Ring
- Shaft
- Door Release Button
- Control Panel
- Oven Air Vent
- Glass Tray
- Grill Heater
- Metal Rack

# CONTROL PANEL

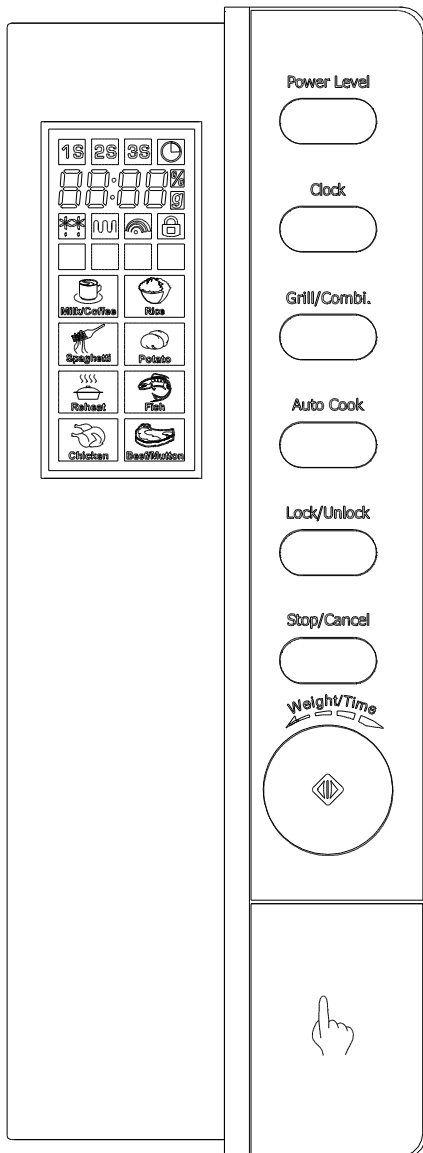

## ● MENU ACTION SCREEN

- ✦ Cooking time, power, action indicators, and clock time are displayed.

## ● POWER LEVEL

- ✦ Touch this button a number of times to set microwave cooking power level.

## ● GRILL/COMBI.

- ✦ Press this button a number of times to access grill cooking mode or two combination cooking settings.

## ● WEIGHT / TIME (DIAL)

- ✦ Turn the dial to set the oven clock time or input cooking time.

- ✦ Turn the WEIGHT/TIME dial to specify weight.

- ✦ Turn the dial to set Auto Defrost program.

## ● AUTO COOK

- ✦ Press a number of times for quick settings to cook popular foods. You need to specify weight.

## ● CLOCK

- ✦ Touch to set the digital clock.

## ● START/QUICK START (DIAL)

- ✦ Touch to start a cooking program.

- ✦ Simply touch it a number of times to set cooking time and the oven will cook immediately at full power level.

## ● STOP/CANCEL

- ✦ Press to cancel setting or reset the oven before setting a cooking program.

- ✦ Press once to temporarily stop cooking, or twice to cancel cooking altogether.

## ● LOCK/UNLOCK

- ✦ Touch to lock or unlock the oven.

# HOW TO SET THE OVEN CONTROLS

Each time a button is touched, a beep will sound to acknowledge the touch.

## Setting Digital Clock

This is a clock in 12-hour or 24-hour cycle.

For example, suppose you want to set the oven clock time to 8:30.

1. Press CLOCK button, "12H" will be displayed, touch the button again if you want to set the clock in 24-hour cycle.
2. Turn WEIGHT/TIME to indicate the hour digit 8.
3. Press CLOCK button.
4. Turn WEIGHT/TIME dial to indicate the minute digits until the screen shows 8:30.
5. Press CLOCK to confirm the setting.

## Microwave Cooking

The longest cooking time is 95 minutes. You can select power level by pressing the button POWER LEVEL for several times as below:

Press the Button	Cooking Power
once	100%
twice	80%
3 times	60%
4 times	40%
5 times	20%
6 times (setting timer)	0

For example, suppose you want to cook for 1 minute at 60% of microwave power.

1. Press the POWER LEVEL button for 3 times.
2. Turn WEIGHT/TIME dial to 1:00.
3. Press START/QUICK START button.

**Note:** You can check the microwave power during cooking by pressing the POWER LEVEL button.

## Grill

The longest cooking time is 95 minutes. The grill cooking is particularly useful for thin slices of meat, steaks, chops, kebabs, sausages or piece of chicken. It is also suitable for hot sandwiches and au gratin dishes.

For example, suppose you want to grill for 12 minutes.

1. Press GRILL/COMBI. button once.
2. Turn the WEIGHT/TIME to 12:00.
3. Press START/QUICK START button.

## Combination 1

The longest cooking time is 95 minutes.

30% time for microwave cooking, 70% for grill cooking. Use for fish, au gratin, etc.

For example: Suppose you want to set combination 1 cooking for 25 minutes.

1. Press GRILL/COMBI. button twice.
2. Turn WEIGHT/TIME to 25:00.
3. Press START/QUICK START button.

## Combination 2

The longest cooking time is 95 minutes.

55% time for microwave cooking, 45% for grill cooking. Use for puddings omelet's, baked potatoes and poultry.

For example, suppose you want to set combination 2 cooking for 12 minutes.

1. Press GRILL/COMBI. button for three times.
2. Turn WEIGHT/TIME to 12:00.
3. Press START/QUICK START button.



## Auto Cook

For food or the following cooking mode, it is not necessary to program the duration and the cooking power. It is sufficient to indicate the type of food that you wish to cook as well as the weight of this food.

For example, suppose you want to cook 400g of fish.

1. Press the AUTO COOK button for 6 times.
2. Turn WEIGHT/TIME dial to indicate a weight of 400g.
3. Press START/QUICK START button.

Auto Cook Menu

Code	Food/cooking mode	Turn WEIGHT/TIME dial to indicate weight of food
A01	Milk/Coffee(200ml/cup)	<p>1. Weight parameters are used to determine the time needed to do the job. As you rotate the WEIGHT/TIME dial, a number of pre-set weight parameters display themselves one by one, when it comes up of the right figure which matches the weight of the food you have placed into the oven, press the START/QUICK START button.</p> <p>2. For chicken, beef/mutton, oven pauses and sound beeps in the middle of cooking time to remind the user to turn over food for uniform cooking.</p>
A02	Rice (g)	
A03	Spaghetti (g)	
A04	Potato (each 230g)	
A05	Reheat (g)	
A06	Fish (g)	
A07	Chicken (g)	
A08	Beef/Mutton (g)	

**Note:** The result of auto cooking depends on factors such as fluctuation of voltage, the shape and size of food, your personal preference as to the doneness of certain foods and even how well you happen to place food in the oven. If you find the result at any rate not quite satisfactory, please adjust the cooking time a little bit accordingly.

## Quick Start

This feature allows you to start the oven quickly.

Press the START/QUICK START button a number of times to set the cooking time, the oven starts working at full power level immediately. The longest cooking time is 10 minutes.

Press the Button	Time
once	0:30
twice	1:00
thrice	1:30
...	...

Suppose you want to set the oven to cook for 2 minutes by using this feature, press the button START/QUICK START for 4 times, the oven will start working immediately at full microwave power.

## Multistage Cooking

Your oven can be programmed for up to 3 automatic cooking sequences.

Suppose you want to set the following cooking program:

Microwave cooking



Grill cooking

1. Press the POWER LEVEL button for several times to set microwave power.
2. Turn WEIGHT/TIME to set cooking time.
3. Press the GRILL/COMBI. button once.
4. Turn WEIGHT/TIME to set cooking time.
5. Press START/QUICK START button.

**Note:** Auto Cook and Auto Defrost cannot be set in the multistage cooking program.

## **Auto Defrost**

---

The oven could be used to defrost food based on the weight you entered. The defrosting time and power level are automatically set once the weight is programmed. The weight varies between 100g and 1800g.

Suppose you want to defrost 600g of shrimp.

1. Place the shrimp to be defrosted into the oven and close the door.
2. Turn WEIGHT/TIME anti-clockwise once, "100g" will be displayed.
3. Turn WEIGHT/TIME to select food weight.
4. Press START/ QUICK START button.

**Note:** During defrosting process, the system

will pause and sound beeps to remind user to turn over the food, and then press START/QUICK START to resume defrosting.

## **Child Lock**

---

Use to prevent unsupervised operation of the oven by little children. The child lock indicator will show up on display, and the oven can not be operated while the Child Lock is set.

To set the Child Lock: Press and hold the LOCK/UNLOCK button for 3 seconds, a beep sounds and lock indicator lights.

To cancel the Child Lock: Press and hold the LOCK/UNLOCK button for 3 seconds until lock indicator on display goes off.

## **CLEANING AND CARE**

1. Turn off the oven and remove the power plug from the wall socket before cleaning.
2. Keep the inside of the oven clean. When food splatters or spilled liquids adhere to oven walls, wipe with a damp cloth. Mild detergent may be used if the oven gets very dirty. Avoid the use of spray and other harsh cleaners as they may stain, streak or dull the door surface.
3. The outside surfaces should be cleaned with a damp cloth. To prevent damage to the operating parts inside the oven, water should not be allowed to seep into the ventilation openings.
4. Wipe the door and window on both sides, the door seals and adjacent parts frequently with a damp cloth to remove any spills or splatters. Do not use abrasive cleaner.
5. Do not allow the control panel to become wet. Clean with a soft, damp cloth. When cleaning the control panel, leave oven door open to prevent oven from accidentally turning on.
6. If steam accumulates inside or around the outside of the oven door, wipe with a soft cloth. This may occur when the microwave oven is operated under high humidity condition. And it is normal.
7. It is occasionally necessary to remove the glass tray for cleaning. Wash the tray in warm sudsy water or in a dishwasher.
8. The roller ring and oven floor should be cleaned regularly to avoid excessive noise. Simply wipe the bottom surface of the oven with mild detergent. The roller ring may be washed in mild sudsy water or dishwasher. When removing the roller ring from cavity floor for cleaning, be sure to replace in the proper position.
9. Remove odors from your oven by combining a cup of water with the juice and skin of one lemon in a deep microwaveable bowl, microwave for 5 minutes. Wipe thoroughly and dry with a soft cloth.
10. When it becomes necessary to replace the oven light, please consult a dealer to have it replaced.
11. The oven should be cleaned regularly and any food deposits removed. Failure to maintain the oven in a clean condition could lead to deterioration of the surface that could adversely affect the life of the appliance and possibly result in a hazardous situation.
12. Please do not dispose this appliance into the domestic rubbish bin; it should be disposed to the particular disposal center provided by the municipalities.