

MICROWAVE OVEN

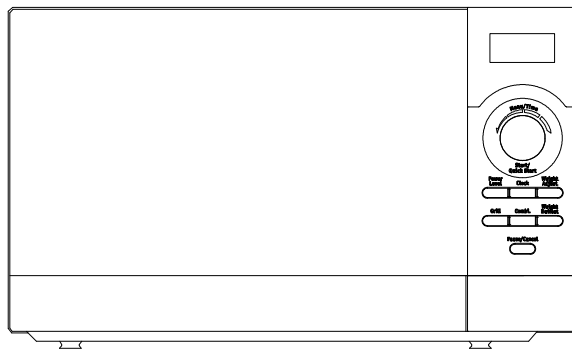

MODEL: **MELCO** MW-900D25 I

Owner 's Manual

Please read these instructions carefully before installing and operating the oven.

Record in the space below the SERIAL NO. found on the nameplate on your oven and retain this information for future reference.

SERIAL NO.

PRECAUTIONS TO AVOID POSSIBLE EXPOSURE TO EXCESSIVE MICROWAVE ENERGY

1. Do not attempt to operate this oven with the door open since open door operation can result in harmful exposure to microwave energy. It is important not to defeat or tamper with the safety interlocks.
2. Do not place any object between the oven front face and the door or allow soil or cleaner residue to accumulate on sealing surfaces.
3. Do not operate the oven if it is damaged. It is particularly important that the oven door close properly and that there is no damage to the
 - a. Door (bent),
 - b. Hinges and latches (broken or loosened),
 - c. Door seals and sealing surfaces.
4. The oven should not be adjusted or repaired by anyone except properly qualified service personnel.

CONTENT

PRECAUTIONS TO AVOID POSSIBLE EXPOSURE TO EXCESSIVE MICROWAVE ENERGY	1
IMPORTANT SAFETY INSTRUCTIONS	2
SPECIFICATIONS	3
INSTALLATION.....	3
RADIO INTERFERENCE	3
MICROWAVE COOKING PRINCIPLES	5
GROUNDING INSTRUCTIONS	5
BEFORE YOU CALL FOR SERVICE.....	5
UTENSILS GUIDE.....	5
PART NAMES.....	5
CONTROL PANEL.....	6
HOW TO SET THE OVEN CONTROLS.....	7
Setting Digital Clock	7
Microwave Cooking.....	7
Quick Start.....	7
Weight Defrost	7
Grill Cooking.....	8
Combination Cooking.....	8
Child Lock	8
Auto Cook	9
CLEANING AND CARE	10

IMPORTANT SAFETY INSTRUCTIONS

When using electrical appliance basic safety precautions should be followed, including the following:

WARNING: To reduce the risk of burns, electric shock, fire, injury to persons or exposure to excessive microwave energy:

1. Read all instructions before using the appliance.
2. Use this appliance only for its intended use as described in this manual. Do not use corrosive chemicals or vapors in this appliance. This type of oven is specifically designed to heat, cook or dry food. It is not designed for industrial or laboratory use.
3. Do not operate the oven when empty.
4. Do not operate this appliance if it has a damaged cord or plug, if it is not working properly or if it has been damaged or dropped. If the supply cord is damaged, it must be replaced by the manufacturer or its service agent or a similarly qualified person in order to avoid a hazard.
5. **WARNING:** When the appliance is operated in the combination mode, children should only use the oven under adult supervision due to the temperatures generated.
6. **WARNING:** Only allow children to use the oven without supervision when adequate instructions have been given so that the child is able to use the oven in a safe way and understands the hazards of improper use.
7. To reduce the risk of fire in the oven cavity:
 - ✧ When heating food in plastic or paper container, check the oven frequently to the possibility of ignition.
 - ✧ Remove wire twist-ties from paper or plastic bags before placing bag in oven.
 - ✧ If smoke is observed, switch off or unplug the appliance and keep the door closed in order to stifle any flames.
 - ✧ Do not use the cavity for storage purposes. Do not leave paper products, cooking utensils or food in the cavity when not in use.
8. **WARNING:** Liquid or other food must not be heated in sealed containers since they are liable to explode.
9. Microwave heating of beverage can result in delayed eruptive boiling, therefore care has to be taken when handle the container.
10. Do not fry food in the oven. Hot oil can damage oven parts and utensils and even result in skin burns.
11. Eggs in their shell and whole hard-boiled eggs should not be heated in microwave ovens since they may explode even after microwave heating has ended.
12. Pierce foods with heavy skins such as potatoes, whole squashes, apples and chestnuts before cooking.
13. The contents of feeding bottles and baby jars should be stirred or shaken and the temperature should be checked before serving in order to avoid burns.
14. Cooking utensils may become hot because of heat transferred from the heated food. Potholders may be needed to handle the utensil.
15. Utensils should be checked to ensure that they are suitable for use in microwave oven.
16. **WARNING:** It is hazardous for anyone other than a trained person to carry out any service or repair operation which involves the removal of any cover which gives protection against exposure to microwave energy.
17. This product is Group 2 Class B ISM equipment. The definition of Group 2 which contains all ISM (Industrial, Scientific and Medical) equipment in which radio-frequency energy is intentionally generated and/or used in the form of electromagnetic radiation for the treatment of material, and spark erosion equipment. For Class B equipment is equipment suitable for use in domestic establishments and in establishments directly connected to a low voltage power supply network which supplies buildings

- used for domestic purpose.
18. This appliance is not intended for use by persons (including children) with reduced physical, sensory or mental capabilities, or lack of experience and knowledge, unless they have been given supervision or

- instruction concerning use of the appliance by a person responsible for their safety.
19. Children should be supervised to ensure that they do not play with the appliance.

SPECIFICATIONS

Power Consumption:	230~240V/50Hz, 1400W(Microwave)
Output:	1000W(grill)
	900W
Operation Frequency:	2450MHz
Outside Dimensions:	281mm(H)×483mm(W)×397mm(D)
Oven Cavity Dimensions:	220mm(H)×340mm(W)×344mm(D)
Oven Capacity:	25Litres
Cooking Uniformity:	Turntable System
Net Weight:	Approx. 14.5 kg

*All data quoted above may be further confirmed or updated.

INSTALLATION

1. Make sure that all the packing materials are removed from the inside of the door.
2. **WARNING:** Check the oven for any damage, such as misaligned or bent door, damaged door seals and sealing surface, broken or loose door hinges and latches and dents inside the cavity or on the door. If there is any damage, do not operate the oven and contact qualified service personnel.
3. This microwave oven must be placed on a flat, stable surface to hold its weight and the heaviest food likely to be cooked in the oven.
4. Do not place the oven where heat, moisture, or high humidity are generated, or near combustible materials.
5. For correct operation, the oven must have sufficient airflow. Allow 20cm of space above the oven, 10cm at back and 5cm at both sides. Do not cover or block any openings on the appliance. Do not remove feet.
6. Do not operate the oven without glass tray, roller support, and shaft in their proper positions.
7. Make sure that the power supply cord is undamaged and does not run under the oven or over any hot or sharp surface.
8. The socket must be readily accessible so that it can be easily unplugged in an emergency.
9. Do not use the oven outdoors.

RADIO INTERFERENCE

Operation of the microwave oven can cause interference to your radio, TV, or similar

equipment.

When there is interference, it may be reduced or eliminated by taking the following measures:

1. Clean door and sealing surface of the oven.
2. Reorient the receiving antenna of radio or television.
3. Relocate the microwave oven with respect to the receiver.
4. Move the microwave oven away from the receiver.
5. Plug the microwave oven into a different outlet so that microwave oven and receiver are on different branch circuits.

MICROWAVE COOKING PRINCIPLES

1. Arrange food carefully. Place thickest areas towards outside of dish.
2. Watch cooking time. Cook for the shortest amount of time indicated and add more as needed. Food severely overcooked can smoke or ignite.
3. Cover foods while cooking. Covers prevent spattering and help foods to cook evenly.
4. Turn foods over once during microwave cooking to speed cooking of such foods as chicken and hamburgers. Large items like roasts must be turned over at least once.
5. Rearrange foods such as meatballs halfway through cooking both from top to bottom and from the center of the dish to the outside.

GROUNDING INSTRUCTIONS

This appliance must be grounded. This oven is equipped with a cord having a grounding wire with a grounding plug. It must be plugged into a wall receptacle that is properly installed and grounded. In the event of an electrical short circuit, grounding reduces risk of electric shock by providing an escape wire for the electric current. It is recommended that a separate circuit serving only the oven be provided. Using a high voltage is dangerous and may result in a fire or other accident causing oven damage.

WARNING Improper use of the grounding plug can result in a risk of electric shock.

Note:

1. If you have any questions about the grounding or electrical instructions, consult a qualified electrician or service person.
2. Neither the manufacturer nor the dealer can accept any liability for damage to the oven or personal injury resulting from failure to observe the electrical connection procedures.

The wires in this cable main are colored in accordance with the following code:

Green and Yellow = EARTH

Blue = NEUTRAL

Brown = LIVE

BEFORE YOU CALL FOR SERVICE

If the oven fails to operate:

1. Check to ensure that the oven is plugged in securely. If it is not, remove the plug from the outlet, wait 10 seconds, and plug it in again securely.
2. Check for a blown circuit fuse or a tripped main circuit breaker. If these seem to be operating properly, test the outlet with

- another appliance.
3. Check to ensure that the control panel is programmed correctly and the timer is set.
 4. Check to ensure that the door is securely

closed engaging the door safety lock system. Otherwise, the microwave energy will not flow into the oven.

IF NONE OF THE ABOVE RECTIFIES THE SITUATION, THEN CONTACT A QUALIFIED TECHNICIAN. DO NOT TRY TO ADJUST OR REPAIR THE OVEN YOURSELF.

UTENSILS GUIDE

1. The ideal material for a microwave utensil is transparent to microwave, it allows energy to pass through the container and heat the food.
2. Microwave cannot penetrate metal, so metal utensils or dishes with metallic trim should not be used.
3. Do not use recycled paper products when microwave cooking, as they may contain small metal fragments which may cause sparks and/or fires.
4. Round /oval dishes rather than square/oblong ones are recommend, as food in corners tends to overcook.
5. Narrow strips of aluminum foil may be used to prevent overcooking of exposed areas. But be careful don't use too much and keep a distance of 1 inch (2.54cm) between foil and cavity.

The list below is a general guide to help you select the correct utensils.

Cookware	Microwave	Grill	Combination
Heat-Resistant Glass	Yes	Yes	Yes
Non Heat-Resistant Glass	No	No	No
Heat-Resistant Ceramics	Yes	Yes	Yes
Microwave-Safe Plastic Dish	Yes	No	No
Kitchen Paper	Yes	No	No
Metal Tray	No	Yes	No
Metal Rack	No	Yes	No
Aluminum Foil & Foil Container	No	Yes	No

PART NAMES

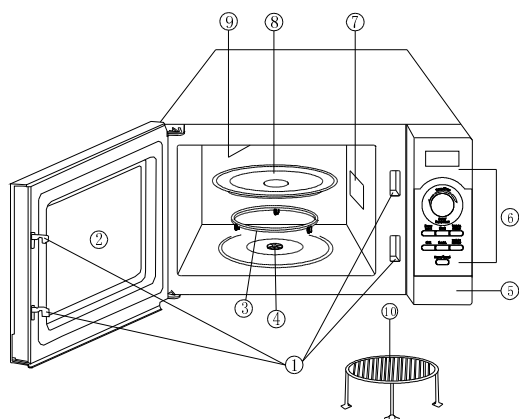

1. Door Safety Lock System
2. Oven Window
3. Turntable Roller
4. Shaft
5. Door Release Button
6. Control Panel
7. Wave Guide
8. Glass Turntable
9. Grill Heater
10. Metal Rack

CONTROL PANEL

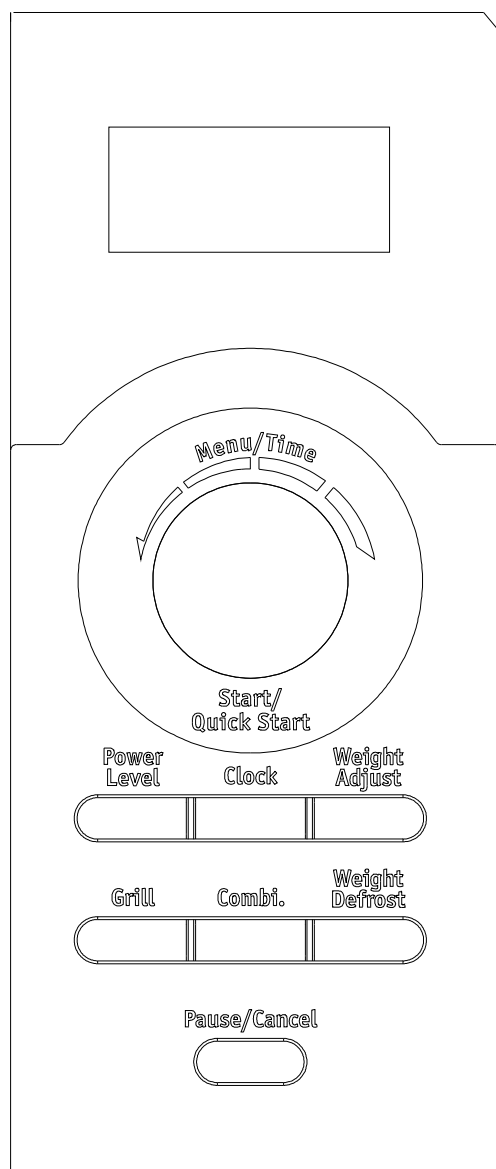

● MENU ACTION SCREEN

× Cooking time, power, action indicators, and clock time are displayed.

● POWER LEVEL

× Press this button a number of times to set microwave cooking power level.

● CLOCK

× Press this button to set the oven clock.

● WEIGHT ADJUST

× Press this button to specify food weight or number of servings.

● WEIGHT DEFROST

× Press to defrost food based on the weight entered.

● COMBI.

× Press to set one of two combination cooking program with microwave and grill.

● GRILL

× Press to set grill cooking program.

● MENU/TIME(DIAL)

× Turn the dial to input cooking time.

× Rotate to select the auto cooking menus.

● START/QUICK START (THE DIAL)

× Press to start a cooking program.

× Press repeatedly to set quick start function.

● PAUSE/CANCEL

× Press to cancel setting or reset the oven before setting a cooking program.

× Press once to temporarily stop cooking, or twice to cancel cooking altogether.

× It is also used for setting child lock.

HOW TO SET THE OVEN CONTROLS

Each time a button is pressed, a beep will sound to acknowledge the press.

SETTING DIGITAL CLOCK

With the oven ready for input, press the CLOCK button once or twice to set the digital clock in 12-hour or 24-hour cycle.

FOR EXAMPLE: Suppose you want to set the oven clock time to 8:30 (12-hour cycle).

1. Press CLOCK button once, when 12H show on screen.
2. Turn MENU/TIME to indicate the hour digit 8.
3. Press CLOCK button once to confirm.
4. Turn MENU/TIME dial to indicate the minute digits until the screen shows 8:30.
5. Press CLOCK to confirm the setting.

You can press the CLOCK button once to check clock time during cooking.

MICROWAVE COOKING

To cook with microwave power alone, press the POWER LEVEL button a number of times to select a cooking power level, and then use the MENU/TIME dial to set a desired cooking time. The longest cooking time is 95 minutes.

Select power level by pressing the POWER LEVEL button:

Press POWER LEVEL button	Cooking power (Display)
once	100%(100)
twice	80%(80)
3 times	60%(60)
4 times	40%(40)
5 times	20%(20)
6 times	0%(00)

For example, suppose you want to cook for 5 minute at 60% of microwave power.

1. Press POWER LEVEL button 3 times.
2. Turn MENU/TIME to 5:00.

3. Press START/QUICK START button.

Note: During cooking, you can check the present cooking power by pressing POWER LEVEL button.

After total time elapsed, the system will sound beeps with END in display. And the beeps will continue to sound every two minutes automatically until the door is opened or any button is pressed.

QUICK START

This feature allows you to start the oven quickly at 100% power.

Press the START/QUICK START a number of times to set the cooking time, the oven starts work at full power level immediately. The maximum cooking time is 10 minutes.

After total time elapsed, the system will sound beeps with END in display. And the beeps will continue to sound every two minutes automatically until the door is opened or any button is pressed.

WEIGHT DEFROST

The oven allows the defrosting of meat, poultry, and seafood. The time and the defrosting power are adjusted automatically once the weight is programmed. The range weight of frozen foods varies between 100g and 1800g.

FOR EXAMPLE: Suppose you want to defrost 600g of shrimp.

1. Place the shrimp to be defrosted into the oven.
2. Press WEIGHT DEFROST button once.
3. Press WEIGHT ADJUST button repeatedly to select the weight of shrimp.
4. Press START/QUICK START button.

Note: Defrost power divides into three stages, each stage needs 1/3 time, after defrosting 2/3 time the system will sound to remind you

to turn over the food and pause until you depress the button START/QUICK START to enter into the next defrosting stage, and the defrosting resume

GRILL COOKING

Grill cooking is particularly useful for thin slices of meat, steaks, chops, kebabs, sausages and pieces of chicken. The longest cooking time is 95 minutes.

For example: Suppose you want to program grill cooking for 12 minutes.

1. Press GRILL button once.
2. Turn MENU/TIME dial to set cooking time 12:00.
3. Press START/QUICK START button.

Note: After total time elapsed, the system will sound beeps with END in display. And the beeps will continue to sound every two minutes automatically until the door is opened or any button is pressed.

COMBINATION COOKING

The longest cooking time in both combination 1 and 2 is 95 minutes.

COMBINATION 1

30% time for microwave cooking, 70% for grill cooking. Use for fish and au gratin.

For example: Suppose you want to set combination 1 cooking for 25 minutes.

1. Press COMBI. button once, when CO-1

display on screen.

2. Turn MENU/TIME dial to enter cooking time 25:00.
3. Press START/QUICK START button.

COMBINATION 2

55% time for microwave cooking, 45% for grill cooking. Use for pudding, omelets, baked potatoes and poultry.

For example: Suppose you want to set combination 2 cooking for 12 minutes.

1. Press COMBI. button twice, when CO-2 display on screen.
2. Turn MENU/TIME to enter cooking time 12:00.
3. Press START/QUICK START button.

Note: during cooking, press COMBI. button to check cooking power.

CHILD LOCK

Use to prevent unsupervised operation of the oven by little children. The CHILD LOCK indicator will show up on display screen, and the oven can not be operated while the CHILD LOCK is set.

To set the CHILD LOCK: Press and hold the PAUSE/CANCEL button for 3 seconds, a beep sounds and lock indicator lights.

To cancel the CHILD LOCK: Press and hold the PAUSE/CANCEL button for 3 seconds until lock indicator on display goes off.

AUTO COOK

For food or the following cooking mode, it is not necessary to program the duration and the cooking power. It is sufficient to indicate the type of food that you wish to cook as well as the weight of this food. In order to do this, rotate the MENU/TIME dial anti-clockwise to select a category of food/cooking mode, and then press WEIGHT ADJUST to indicate weight of food to be cooked. The oven begins cooking once the START/QUICK START button is engaged.

You may need to turn food over at the middle of cooking time to obtain uniform cooking.

For example: to cook 400g of fish.

1. Turn MENU/TIME dial anti-clockwise until code 6 displays.
2. Press WEIGHT ADJUST to indicate the weight of 400g.
3. Press START/QUICK START button.

Auto Cook Menu

Code	Food/cooking mode	
1	Milk/Coffee (200ml/cup)	<ol style="list-style-type: none">1. Press WEIGHT ADJUST to select weight or amount of food.2. For Spaghetti add boiling water before cooking3. For chicken, beef/mutton, skewered meat, during cooking, the system will sound beep and pause to remind you to turn food over for uniform cooking, then close door and press START/QUICK START to resume cooking.4. The result of auto cooking depends on factors such as fluctuation of voltage, the shape and size of food, your personal preference as to the doneness of certain foods and even how well you happen to place food in the oven. If you find the result at any rate not quite satisfactory, please adjust the cooking time a little bit accordingly.
2	Rice (g)	
3	Spaghetti (g)	
4	Potato (230g/unit)	
5	Auto Reheat (g)	
6	Fish (g)	
7	Chicken (g)	
8	Beef/Mutton (g)	
9	Skewered Meat(g)	

CLEANING AND CARE

1. Turn off the oven and remove the power plug from the wall socket before cleaning.
2. Keep the inside of the oven clean. When food splatters or spilled liquids adhere to oven walls, wipe with a damp cloth. Mild detergent may be used if the oven gets very dirty. Avoid the use of spray and other harsh cleaners as they may stain, streak or dull the door surface.
3. The outside surfaces should be cleaned with a damp cloth. To prevent damage to the operating parts inside the oven, water should not be allowed to seep into the ventilation openings.
4. Wipe the both sides of the door and window, the door seals and adjacent parts frequently with a damp cloth to remove any spills or splatters. Do not use abrasive cleaner.
5. Do not allow the control panel to become wet. Clean with a soft, damp cloth. When cleaning the control panel, leave oven door open to prevent oven from accidentally turning on.
6. If steam accumulates inside or around the outside of the oven door, wipe with a soft cloth. This may occur when the microwave oven is operated under high humidity condition. And it is normal.
7. It is occasionally necessary to remove the glass tray for cleaning. Wash the tray in warm sudsy water or in a dishwasher.
8. The roller ring and oven floor should be cleaned regularly to avoid excessive noise. Simply wipe the bottom surface of the oven with mild detergent. The roller ring may be washed in mild sudsy water or dishwasher. When removing the roller ring from cavity floor for cleaning, be sure to replace in the proper position.
9. Remove odors from your oven by combining a cup of water with the juice and skin of one lemon in a deep microwaveable bowl, microwave for 5 minutes. Wipe thoroughly and dry with a soft cloth.
10. When it becomes necessary to replace the oven light, please consult a dealer to have it replaced.
11. The oven should be cleaned regularly and any food deposits removed. Failure to maintain the oven in a clean condition could lead to deterioration of the surface that could adversely affect the life of the appliance and possibly result in a hazardous.
12. Please do not dispose this appliance into the domestic rubbish bin; it should be disposed to the particular disposal center provided by the municipalities.

Specifications subject to change without notice